

## Trailer-Mounted Generator Set with KRP250 Switchgear

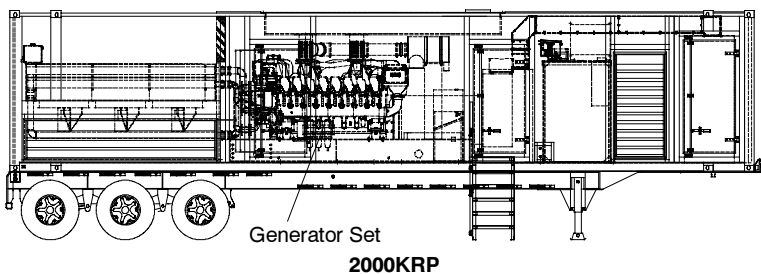
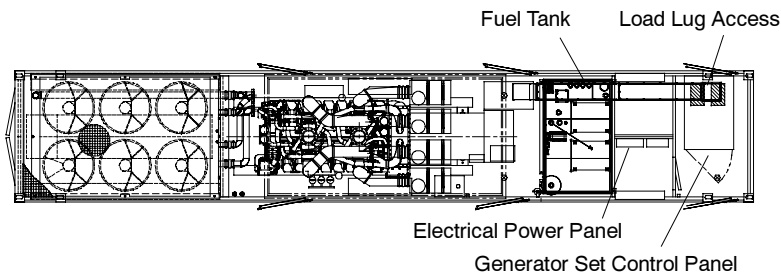
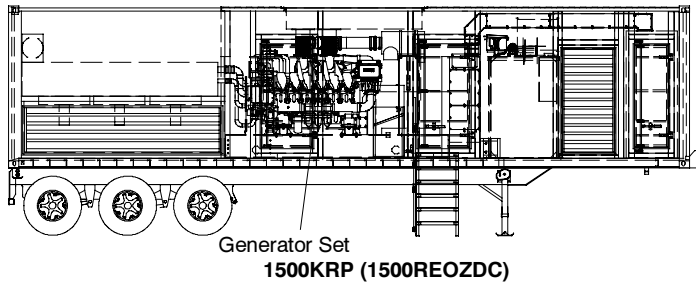
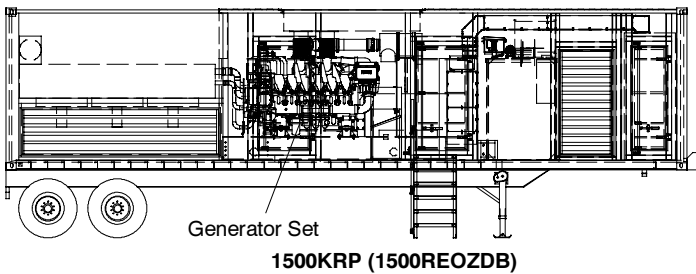
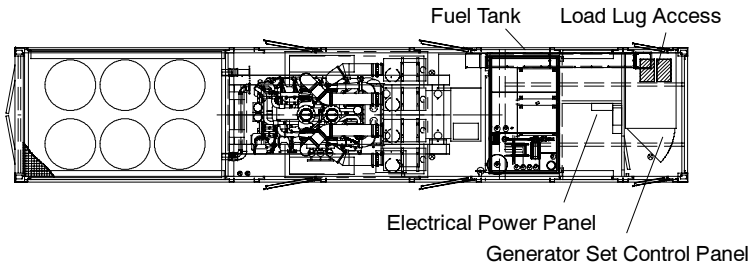

- Kohler Rental Power provides one-source responsibility for the generator set and switchgear system.
- Generator set features:
  - Premium sound-attenuated ISO container
  - Emergency stop switch mounted at the floor inside of the engine room door
  - Internal fuel tank with fill/spill feature and secondary fluid containment basin sized at 115% of total volume
  - Hospital-grade silencer and rain cap with non-bypass turbocharger exhaust system meeting U.S. Forestry spark arrestor requirements
  - AC input connection (shore power) box for block heater and battery charger
  - Easy access cable and load lug hatch
  - Generator set and switchgear manufactured by Kohler Power Systems
- Engine features:
  - Closed crankcase ventilation system
  - Electronic isochronous governor providing precise frequency regulation
  - Engine block heater
  - Engine oil makeup system
  - Fuel/water separator with bypass valve
  - Heavy-duty air cleaner with air restriction indicator
- Trailer features:
  - Generator set control room with separate outside access door
  - Fire extinguisher
  - Interior work lights with timer
  - Six access doors with stowable stairs and safety railing
  - Running lights with standard DOT 7-way receptacle
- Remote monitoring (GPS) features:
  - Issues alerts for low oil pressure, low fuel level, and common faults
  - Issues alerts for unauthorized movement of equipment
  - Monitors and issues reports for service intervals
  - Tracks low battery conditions

## Trailer-Mounted Generator Set Specifications

Model (Unit Numbers)	Generator Set Model	Trailer† Length mm (in.)	Trailer† Width mm (in.)	Trailer† Height mm (in.)	Gross Weight* kg (lb.)	Ambient Temperature, °C (°F)	Sound Level dBA with 3/4 Load at 15 m (50 ft.)
1500KRP (1501045-1501049)	1500REOZDB	12192 (480)	2438 (96)	4115 (162)	31389 (69200)	45 (113)	74
1500KRP (>1501050)	1500REOZDC				30463 (67160)		
2000KRP (all units)	2000REOZDB	13716 (540)			34645 (76380)		

\* Gross weight includes trailer, generator set, and fuel tank without fuel.

† Trailer dimensions include the enclosure, chassis, and axle/wheels.

## Generator Set Specifications

Model	Generator Set Model	Alternator Model	130°C Rise Standby Rating		105°C Rise Prime Rating		Altitude Derate	Temperature Derate
			480 Volt, 3 Phase		480 Volt, 3 Phase			
			Amps	kW/kVA	Amps	kW/kVA		
1500KRP	1500REOZDB	7M4052	2225	1500/1875	2045	1360/1700	Derate 1% per 100 m (328 ft.) elevation above 400 m (1312 ft.)	Derate 2.0% per 5°C (9°F) temperature above 40°C (104°F)
1500KRP	1500REOZDC	7M4050						
2000KRP	2000REOZDB	7M4058	3007	2000/2500	2736	1820/2275		

See the respective spec sheets for specifications not shown. See the Additional Literature table for generator set and controller spec sheet part numbers.

Model	Generator Set Model	Engine	Fuel Consumption at Standby Rating, Lph (gph)			Fuel Consumption at Prime Rating, Lph (gph)			Fuel Tank L (gal.)
			50% Load	75% Load	100% Load	50% Load	75% Load	100% Load	
1500KRP	1500REOZDB	DDC Series 4000	207.2 (54.7)	296.4 (78.3)	389.4 (102.9)	189.1 (50.0)	269.3 (71.1)	348.5 (92.1)	3785 (1000)
1500KRP	1500REOZDC	DDC Series 4000	226.5 (59.8)	324.3 (85.7)	422.2 (111.5)	201.0 (53.1)	286.7 (75.7)	367.9 (97.2)	3785 (1000)
2000KRP	2000REOZDB	DDC Series 4000	274.1 (72.4)	395.8 (104.6)	520.0 (137.4)	238.6 (63.0)	342.1 (90.4)	451.4 (119.3)	3785 (1000)

See the respective spec sheets for specifications not shown. See the Additional Literature table for generator set and controller spec sheet part numbers.

## Electrical Power Panel Specifications

Model	Load Lug Connections	Circuit Breaker Trip Setting, Amps @ 480 Volt,	Shore Power Connection for Battery Charger and Block Heater	Remote Start Cap- ability
1500REOZDB	(8) 1/0-750 kcmil	2500	Screw terminal block	Yes
1500REOZDC				
2000REOZDB		(9) 1/0-750 kcmil		

## Accessories and Additional Literature

### Power Accessories

- Cable and cable ramps
- Disconnects
- Distribution boxes
- I-line panels
- Light towers
- Transformers
- \_\_\_\_\_
- \_\_\_\_\_
- \_\_\_\_\_

### Other Equipment

- Chillers and accessories
- Heating/cooling units
- Luxury restrooms

### Additional Literature

Generator Set Model	Gen. Set Spec Sheet	Controls
1500REOZDB	G5-229	Woodward GCP-30, TP-6620 Function/Operation Manual, TP-6621 Installation Manual
1500REOZDC	G5-326	
2000REOZDB	G5-231	

## Switchgear Features

- These sophisticated Power Control Systems combine a generator set and switchgear with paralleling capabilities for up to fourteen other KRP250s and/or a single utility providing prime or standby power for critical situations.
- The design allows for automatically starting, stopping, and paralleling the generator sets.
- Paralleling system provides generator set paralleling with a single utility source for base load/peak shaving operation.
- Main bus sized for the standby current rating; bus bracing designed for fault current equal to the circuit breaker fault current.
- The switchgear supports 277/480 VAC, 3-phase, 4-wire, 60 Hz electrical systems.
- UL-891 listed and labeled.
- Service entrance rated.
- Metering setup, control, and monitoring via the door mounted digital paralleling controller.
- Multifunction utility-grade intertie protective relay.
- Full capacity neutral bus.
- Modes of operation:
  - Prime power
  - Emergency
  - Isolate
  - Import/export
  - Base load generator
- Automatic synchronizer.
- Over/Undervoltage. Provides voltage protection by opening the generator set circuit breaker when voltage strays outside of preset parameters.
- Over/Underfrequency. Provides frequency protection by opening the generator set circuit breaker when frequency strays outside of preset parameters.
- Reverse Power. Provides reverse-power protection by opening the generator circuit breaker when reverse power exceeds a preset limit for a preset length of time.

### Intertie Protective Relays

The multifunction intertie protective relay offers the following protection:

- Phase undervoltage
- Phase overvoltage
- Over/underfrequency
- Negative sequence current
- Negative sequence voltage
- Rate of change frequency
- Reverse power

## Component Specifications

### Environmental Requirements

Ambient operating temperature rating of  $-20^{\circ}\text{C}$  to  $70^{\circ}\text{C}$  ( $-4^{\circ}\text{F}$  to  $158^{\circ}\text{F}$ ).

### Cable Connections

Drilled bus bars and set screw-type Cu/Al cable lugs are standard for utility and load connections.

### Circuit Breakers

The electrically operated circuit breakers are UL listed. They are equipped with shunt trip and a microprocessor-based, true RMS sensing trip unit for overload and short circuit protection. The utility circuit breaker is a service entrance-rated, draw-out type mounted on the switchgear panel and includes ground fault protection. The generator set circuit breaker is fixed and mounted on the generator set.

### Generator Set Power Controller

A microprocessor-based generator set power controller contains the system logic, automatic synchronizer, and generator load control.

### Generator Protective Relays

A microprocessor-based, multifunction generator power control and management module provides all generator relaying and control functions.

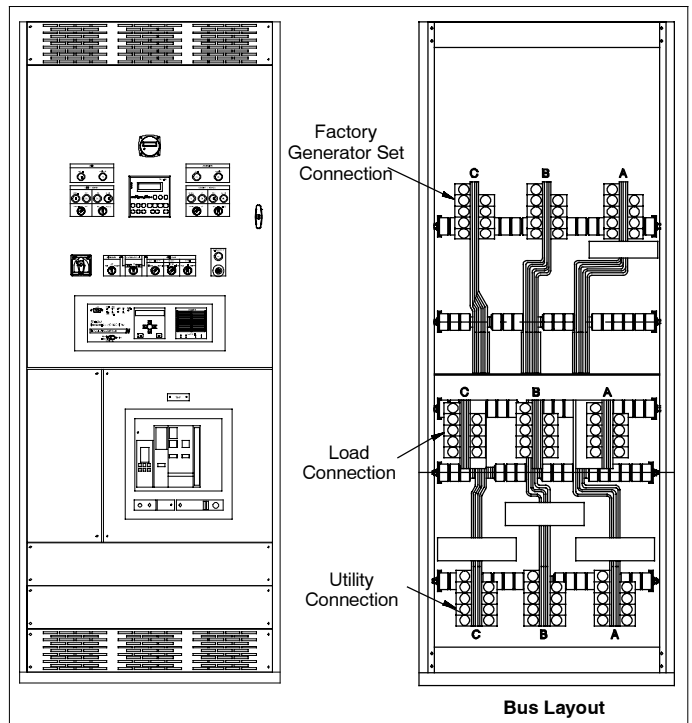

## Mode of Operation

### Prime Power/Remote ATS Start

The utility breaker remains open. If the prime mode switch is in the remote position and a remote start signal is received, the generator set starts. When the generator set reaches rated voltage and frequency and the load is dead, the generator set breaker closes. If the load bus is live, the generator set synchronizes and then closes. If the prime mode switch is placed in the run position, the generator set starts and functions as stated above.

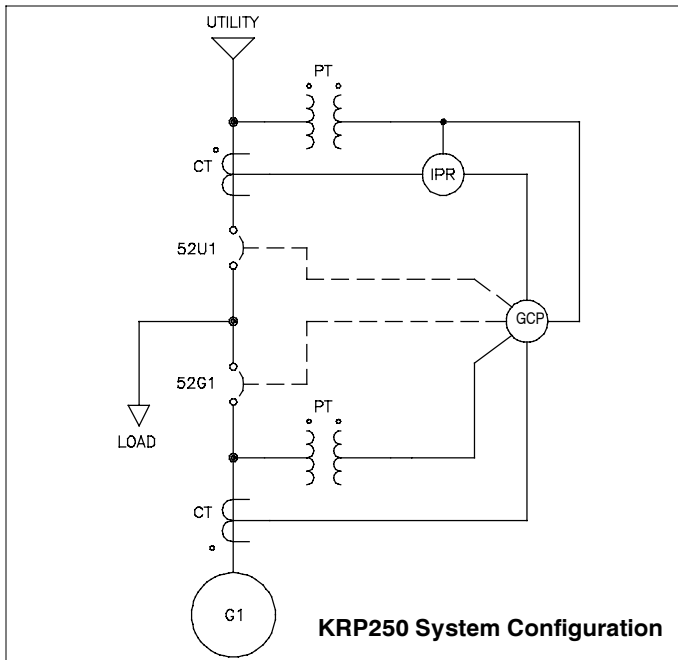

**KRP250 System Configuration**

### Emergency Standby (Standard)

#### Loss of Utility

If the utility fails, the utility breaker opens and the switchgear starts the generator set, supplying power to the load.

If the system is running in parallel to the utility and the utility fails, the utility breaker opens and the system goes into emergency/standby mode while still supplying power to the load.

#### Return of Utility

After utility power is restored, the return-to-utility sequence starts.

**Open Transfer:** The generator set breaker opens and, after a time delay, the utility breaker closes.

**Soft-Load (Closed) Transfer:** The generator set synchronizes to the utility. When synchronized, the utility breaker closes. The switchgear soft-unloads the generator set and opens the generator set breaker.

Availability is subject to change without notice. Kohler Co. reserves the right to change the design or specifications without notice and without any obligation or liability whatsoever. Contact your local Kohler<sup>®</sup> Rental regional office for availability.

### No Load Test

The generator set starts and accelerates to rated voltage and frequency. The generator set breaker remains open and the switchgear does not transfer load.

### Isolate/Load Test

The generator set synchronizes to the utility. When synchronized, the generator set breaker closes. The switchgear soft-loads the generator set. When the utility is unloaded, the utility breaker opens.

### Base Load Generator

The generator set synchronizes to the utility. When synchronized, the generator set breaker closes. The generator set soft-loads to a user-adjustable kW level. Generator set output remains constant and utility power fluctuates to supply the difference between the generator set output and the load requirement.

When the generator set output exceeds the system load requirements, the excess power can be exported to the utility. If the system load requirements exceed the generator set output, the utility supplies the difference to meet the load requirements.

### Import/Export

The generator set synchronizes to the utility. When synchronized, the generator set breaker closes. The generator set soft-loads to a user-adjustable kW power flow across the utility breaker. The power flow to the utility remains constant and the generator set power output fluctuates to meet the requirements of the load.

If the import/export level is positive, the system imports a set power level from the utility; if the import/export level is negative, the system exports a set power level to the utility. If the load requirement exceeds the generator set rating, the generator set produces its rated power and the utility supplies the difference.

### System Start

Initiate a system start using one or more of the following methods:

- Utility failure
- Local operator interface (network or dry contact)
- Remote contact closure

### DISTRIBUTED BY:

